

**Atlas Copco**

# Cast iron piston compressors

Automan Industrial: ATC 2 stage oil-lubricated Piston  
(3-10 hp / 2.2-7.5 kW - 50Hz)

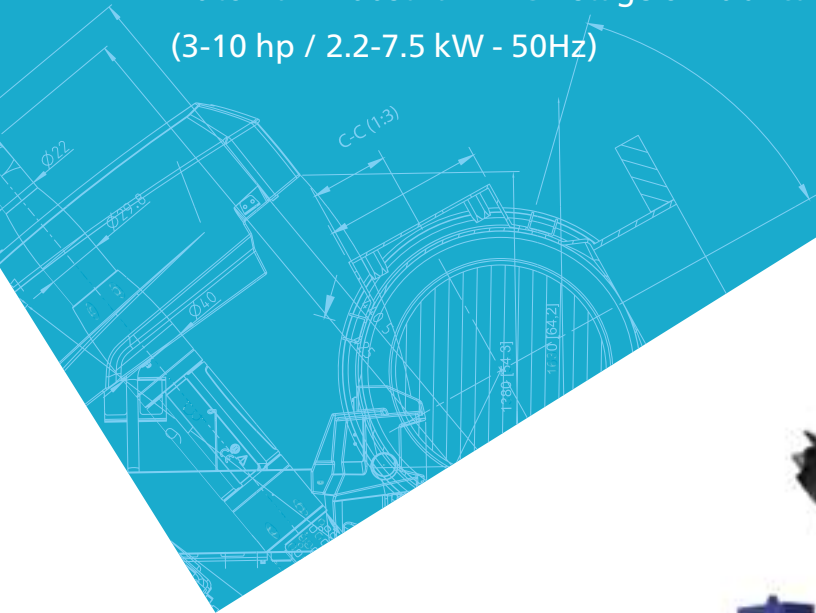

## Robust, reliable and heavy duty

The Automan series has been designed for maximum productivity and longer lifetime. Every component has been engineered, tested and qualified to guarantee the highest quality. This series stands out because of its durability, cost efficiency and usage in all types of environments.



## Features & benefits



### Heavy duty

- Highly durable design
- Built for any industry
- Performance service kits are available



### Extreme & ductile

- Proven piston technology
- Different versions available



Tank-mounted  
3-5.5 hp



Tank-mounted  
7.5 hp



Tank-mounted  
10 hp

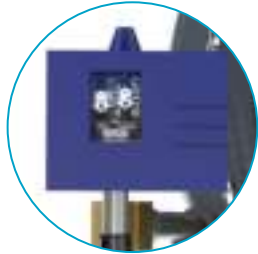

**Pressure switch**  
Installed on all models to maximize reliability and performance.



**Metallic Belt guard**  
For safe operation



**Air receiver**  
200L/270L to meet your needs



**Safety valve and pressure gauge**  
For safety and pressure reading.



**Standard unit:**  
With Starter Panel Bracket  
**Option:**  
With Starter Panel

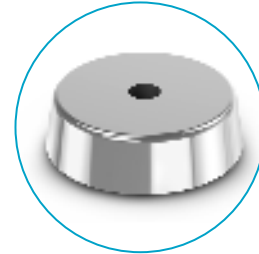

**Anti vibration padding**  
Anti vibration pad for zero vibration transmission and smooth running

## Technical specifications

Model	Maximum PRESSURE		MOTOR POWER		Piston Displacement			Tank		L x B x H				Weight			
	bar	psi	hp	kW	l/min	cfm	m <sup>3</sup> /h	L	rpm	mm		in		kg	lb		
ATC 30/15 200L	12	175	3.0	2.2	340	12.0	20.4	200	580	1443	491	1024	57	19	40	163	359
ATC 55/20 200L	12	175	5.5	3.7	566	20.0	34.0	200	812	1443	491	1024	57	19	40	171	377
ATC 75/25 200L	12	175	7.5	5.5	708	25.0	42.5	200	925	1443	491	1024	57	19	40	191	421
ATC 75/30 200L	12	175	7.5	5.5	850	30.0	51.0	200	975	1443	491	1024	57	19	40	191	421
ATC 100/40 200L	12	175	10.0	7.5	1076	38.0	64.6	200	1180	1443	491	1024	57	19	40	200	441
ATC 30/15 270L	12	175	3.0	2.2	340	12.0	20.4	270	580	1551	521	1068	61	21	42	174	384
ATC 55/20 270L	12	175	5.5	3.7	566	20.0	34.0	270	812	1551	521	1068	61	21	42	168	370
ATC 75/25 270L	12	175	7.5	5.5	708	25.0	42.5	270	925	1551	521	1068	61	21	42	202	445
ATC 75/30 270L	12	175	7.5	5.5	850	30.0	51.0	270	975	1551	521	1068	61	21	42	220	485
ATC 100/40 270L	12	175	10.0	7.5	1076	38.0	64.6	270	1180	1551	521	1068	61	21	42	220	485

## Service kits and spare parts

The Atlas Copco ATC is supported by a full range of service kits that come complete with all necessary parts and oils.

- Genuine parts guarantee extended compressor service life and reliability.
- Cost-effective service solution based on optimum service intervals.
- Save time and administration - no need to determine individual service parts.
- Off-the-shelf availability.
- Atlas Copco's Piston Oil was specifically developed to offer sustainable lubricant properties even under demanding operating conditions.

## Dimensions

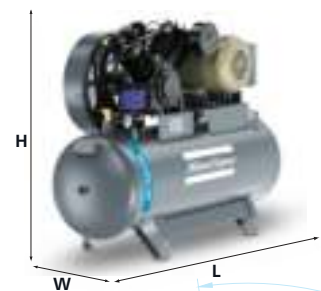

www.atlascopco.com